



US 20050201090A1

(19) **United States**

(12) **Patent Application Publication**  
**Knight**

(10) **Pub. No.: US 2005/0201090 A1**

(43) **Pub. Date: Sep. 15, 2005**

(54) **ANGLE ADJUSTMENT DEVICE**

**Publication Classification**

(76) **Inventor: Richard Knight, Dorset (GB)**

Correspondence Address:  
**FORTKORT GREYER + KELTON LLP**  
**8911 N. CAPITAL OF TEXAS HWY.**  
**SUITE 3200**  
**AUSTIN, TX 78759 (US)**

(51) **Int. Cl.<sup>7</sup> ..... F21V 9/00**  
(52) **U.S. Cl. .... 362/230; 362/252**

(57) **ABSTRACT**

(21) **Appl. No.: 11/121,595**

(22) **Filed: May 3, 2005**

**Related U.S. Application Data**

(63) **Continuation of application No. 10/043,214, filed on Jan. 14, 2002.**

An angle adjustment device comprises a support member, a plurality of holders for light emitting or receiving devices, each holder being supported by the support member for pivoting about at least one axis and an elongate spiral element which co-operates with the holders so that when the spiral element is displaced angularly about its axis relative to the support member, each holder pivots about its said at least one axis.

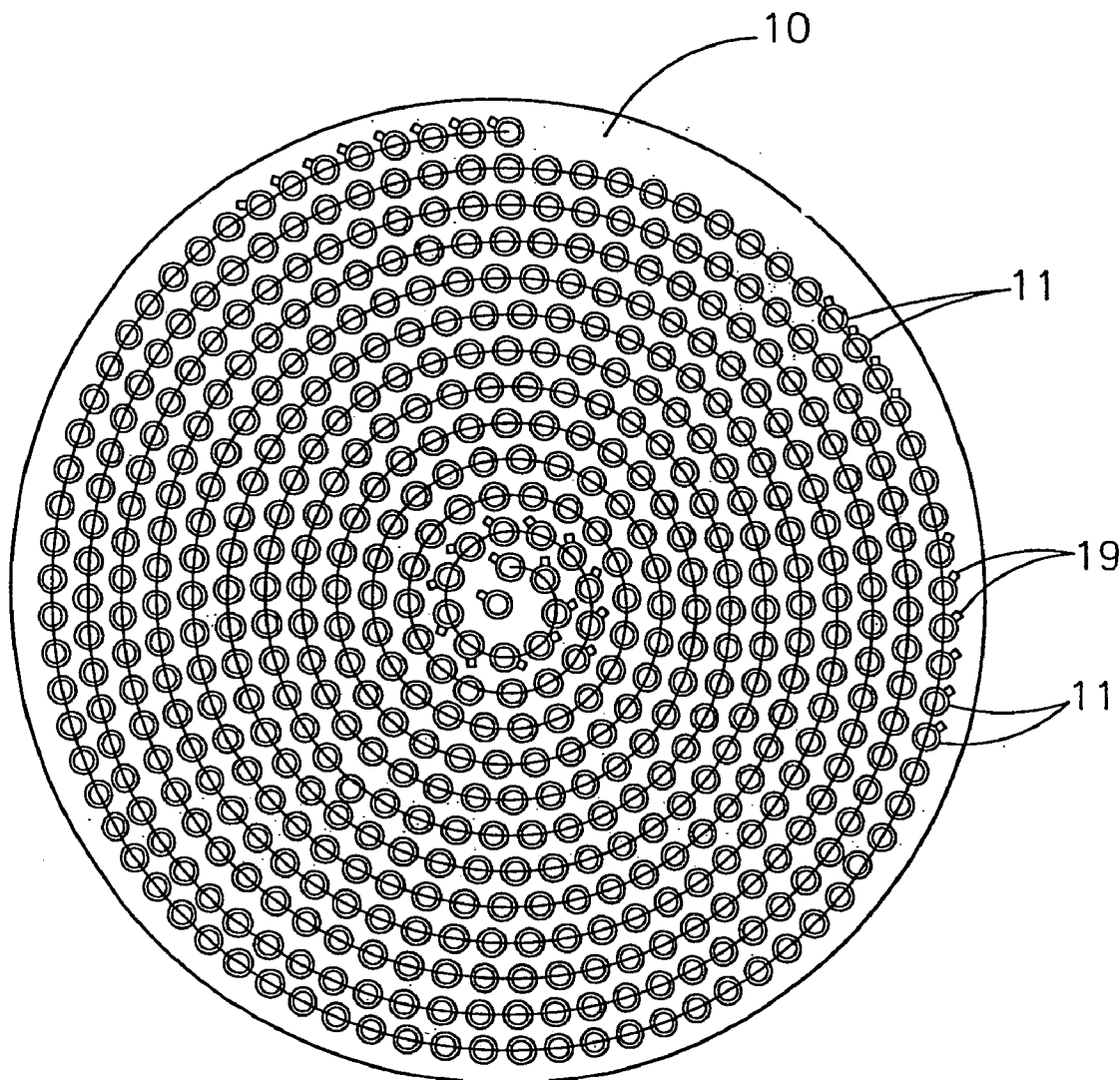

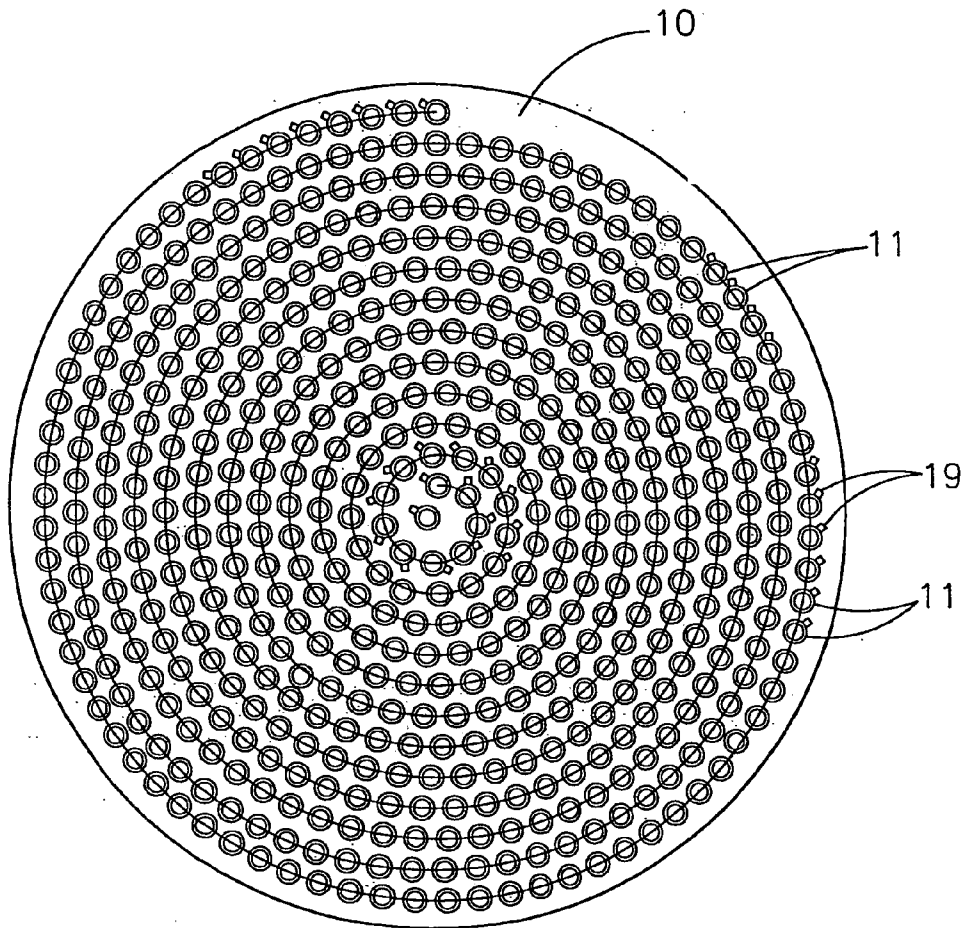

FIG 1

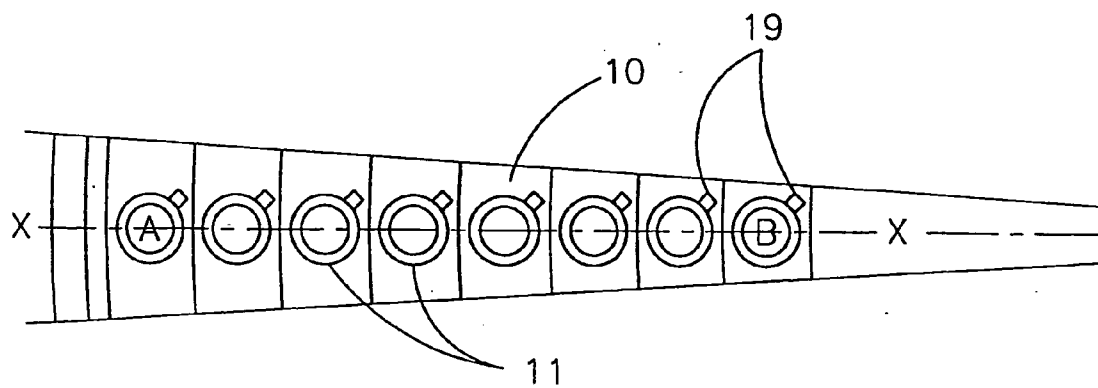

FIG 2



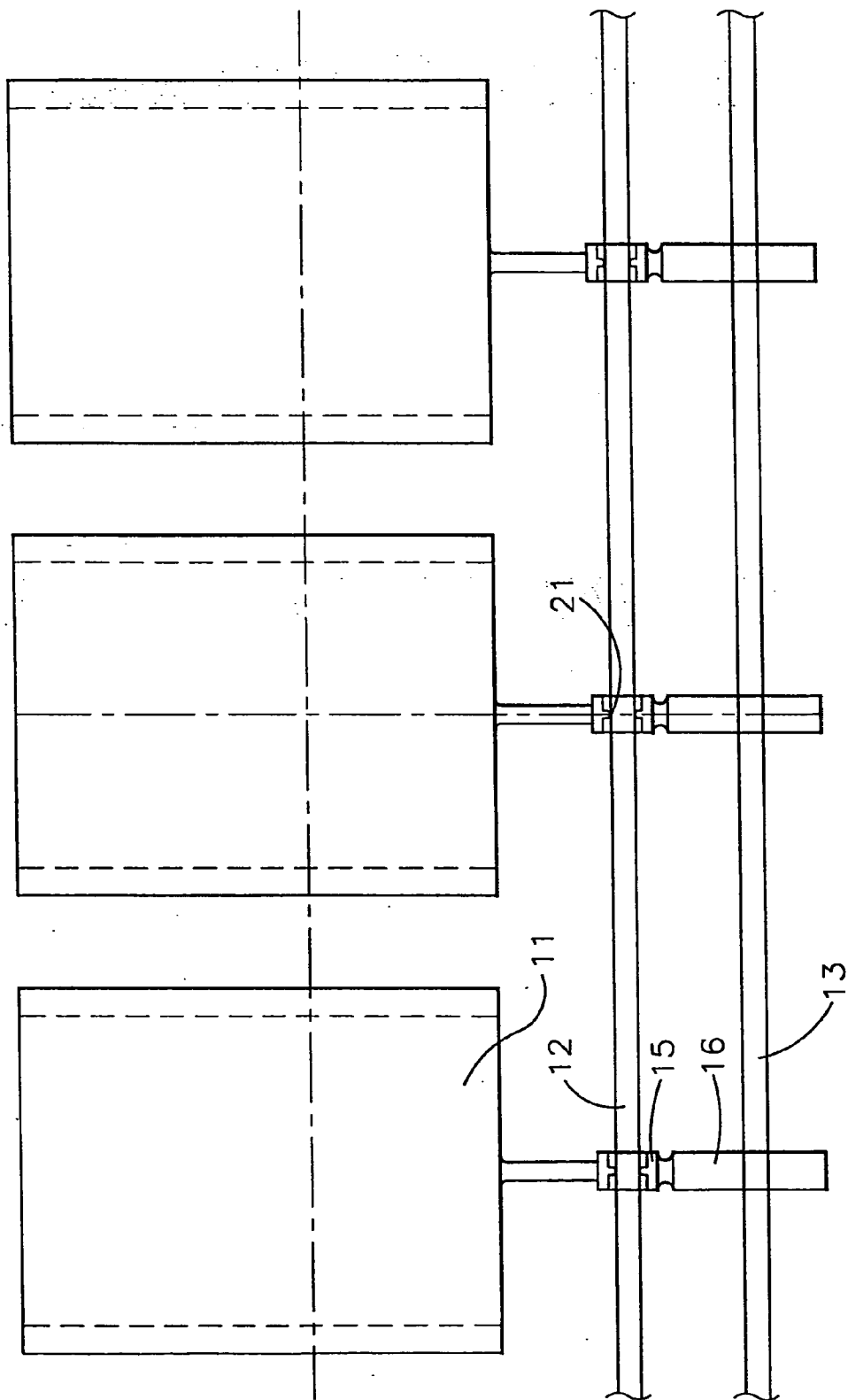

FIG 4

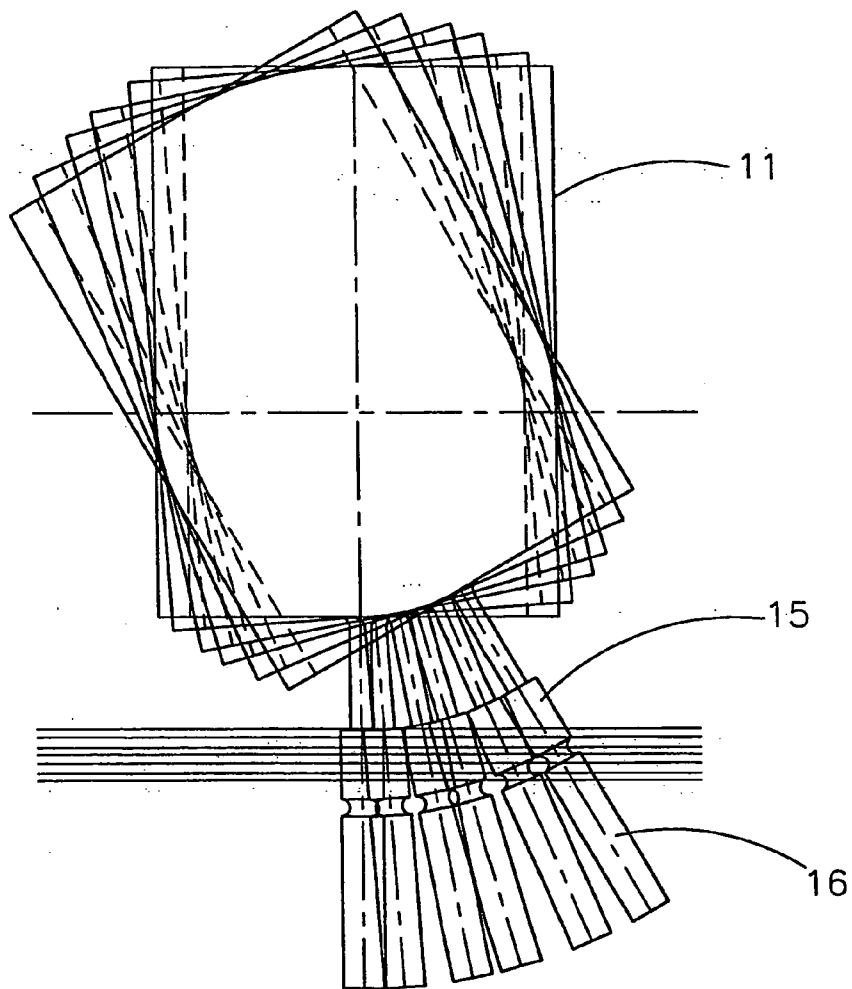

FIG 5

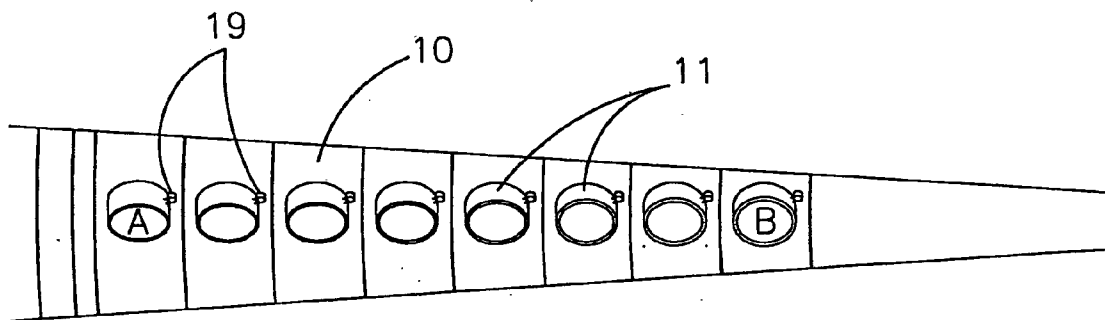

FIG 6

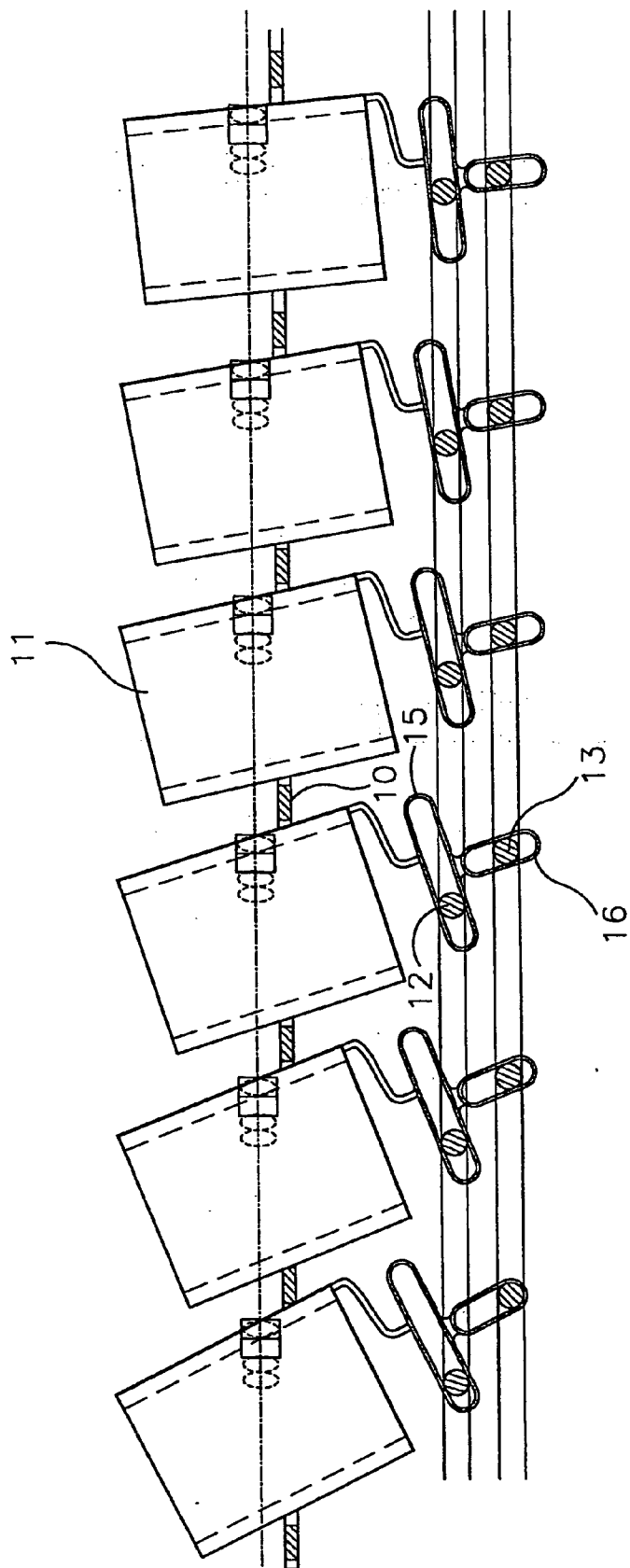

FIG 7

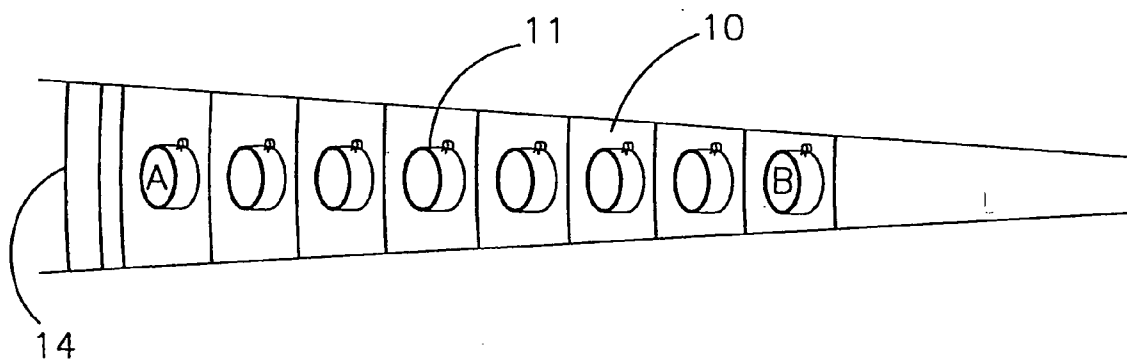

FIG 8

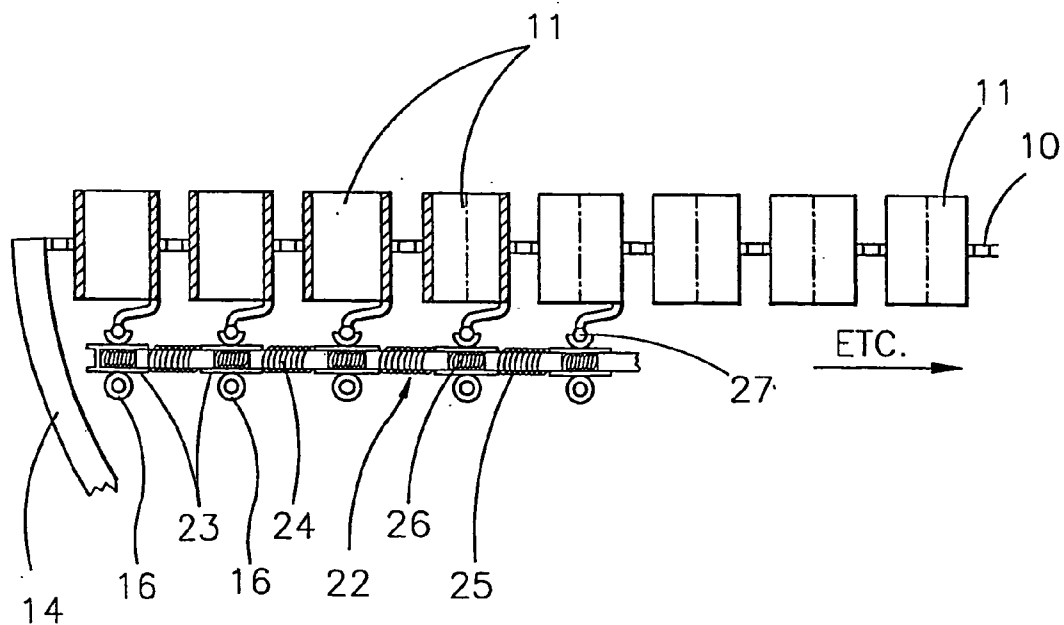

FIG 9

### ANGLE ADJUSTMENT DEVICE

[0001] This invention relates to an angle adjustment device and more particularly but not exclusively to such a device for changing a beam of light produced by a plurality of light emitting devices, such as light emitting diodes or fibre optics. Such a device has particular application in automated lighting.

### SUMMARY OF THE INVENTION

[0002] According to one aspect of the present invention there is provided an angle adjustment device comprising a support member, a plurality of holders for light emitting or receiving devices, each holder being supported by the support member for pivotable movement about at least one axis, and an elongate spiral element which co-operates with the holders so that when the spiral element is displaced angularly about its axis relative to the support member, each holder pivots about its said at least one axis.

[0003] Preferably, said at least one axis of each holder extends perpendicularly or substantially perpendicularly to a radius extending outwardly from the axis of the spiral and through the holder.

[0004] Preferably, the spiral element passes through an aperture in each holder or in a part connected to each holder and is slidable relative to each holder when displaced angularly.

[0005] Preferably, means (typically an electric motor) is provided for angularly displacing the spiral element about its axis.

[0006] Preferably, the holders are spaced apart on the support member along a spiral path. Alternatively, the holders may be spaced apart on the support member in concentric circles.

[0007] Advantageously, each holder is connected to the support member by a universal joint. In this case, one or more angularly displaceable members may be connected to the holders so that when the angularly displaceable member(s) is/are displaced angularly relative to the support member, each holder pivots about a second axis extending perpendicularly or substantially perpendicularly to said one axis. The angularly displaceable member(s) is/are typically in the form of a further spiral or a plurality of spokes extending radially outwards from the axis of the first mentioned spiral. Means (typically a second electric motor) may be provided for angularly displacing the angularly displaceable member(s) relative to the support member.

[0008] The angle adjustment device may also comprise a plurality of light emitting devices supported by the holders. The light emitting devices are preferably in the form of light emitting diodes (LED's) and typically in form of white LED's each having red, blue and green guns, but they could be in the form of fibre optics.

[0009] The support member may be capable of flexing and means (typically a third electric motor) may be provided for flexing the support member between a planar condition and a bowl-shaped and/or dome-shaped condition.

[0010] According to a further aspect of the invention there is provided automated lighting having a source of light formed by a plurality of white light emitting diodes.

[0011] The invention will now be more particularly described, by way of example, with reference to the accompanying drawings.

### BRIEF DESCRIPTION OF THE DRAWINGS

[0012] FIG. 1 is a plan view of one embodiment of an angle adjustment device according to the invention,

[0013] FIG. 2 is a fragmentary plan view of part of the angle adjustment device of FIG. 1 on an enlarged scale,

[0014] FIG. 3 is a section taken along the line X-X of FIG. 2 on a much enlarged scale,

[0015] FIG. 4 is a view generally at right angles to the view of FIG. 3,

[0016] FIG. 5 is a side view showing the manner in which a holder is deflected about a radially outwardly extending axis,

[0017] FIG. 6 is a plan view similar to FIG. 2 but showing the holders deflected about the radially extending axis,

[0018] FIG. 7 is a side view showing the holders deflected about an axis perpendicular to the radially extending axis,

[0019] FIG. 8 is a plan view similar to FIG. 2 but showing the holders deflected about the axis perpendicular to the radially extending axis, and

[0020] FIG. 9 is a view similar to FIG. 3 of another embodiment of an angle adjustment device according to the invention.

### DESCRIPTION OF THE PREFERRED EMBODIMENT

[0021] Referring firstly to FIGS. 1 to 8 of the drawings, the angle adjustment device shown therein comprises a support member 10, a plurality of LED holders 11 supported by the support member 10 and two spiral elements 12 and 13.

[0022] The support member 10 is in the form of a tightly wound spiral which is punched out of sheet material, typically plastics material or an aluminium alloy, and which is capable of flexing for a purpose which will become apparent hereinafter. The support member 10 is mounted in a retaining bowl 14 and has its outer peripheral edge secured to the lip of the bowl 14.

[0023] The LED holders 11 are connected to the support member 10 by universal joints 19 so that the holders 11 can pivot relative to the support member 10.

[0024] Each holder 11 has two eyelets 15 and 16. The eyelet 15 has an elongate horizontally extending slot 17 and the eyelet 16 has an elongate vertically extending slot 18.

[0025] The first and second elongate spiral elements 12 and 13, typically formed from relatively rigid wire, are wound through the eyelets 15 and 16, respectively. The spiral element 13 is not attached to the eyelets 16 but is slidable relative thereto and is rotatable relative to the support member 10 by an electric motor (not shown). Rotation of the spiral element 13 will move the eyelets 16 radially inwards or radially outwards depending on the direction of rotation of the spiral element 13 and this will cause the holders 11 to tilt as shown in FIGS. 7 and 8. If the spacing between all turns of the spiral is equal and if the

outer end of the spiral element **13** is free and allowed to wind into and out of a guide slot located around the inside of the bowl **14**, all holders **11** will be deflected by equal amounts. If the outer end of the spiral element **13** is clamped or driven by a motor at a different speed from the inner end, rotation of the spiral element **13** at the centre will cause unequal deflection of the inner and outer holders **11**. Assuming a clockwise wound spiral element **13**, clamping the outer edge of the spiral whilst the centre of the spiral element is rotated in an anti-clockwise direction will result in an increase in the spacing between the outer turns of the spiral element **13** and a tightening of the inner coils. The outer holders will then deflect more than the inner holders. If the spiral element **13** is wound so that the spacing between turns increases as it winds outwards, the outer holders will deflect more than the inner holders. Conversely, if the spiral element **13** is wound so that the spacing between turns decreases as it winds outwards, the inner holders will deflect more than the outer holders.

[0026] The spiral element **12** is held captive with respect to the eyelets **15** of each holder **11** so that the spiral element **19** can slide along the slot **17** but cannot slide relative to the eyelet in the direction of the longitudinal extent of the spiral. This can be done as shown in **FIG. 4** by providing indents **21** in the spiral element **12** in which the eyelet **15** engages or by collars or washers (not shown) fixed to the spiral element **12** on opposite sides of the eyelet **15**. The spiral element **12** is angularly displaceable relative to the support member **10** by a second electric motor (not shown). Such angular movement of the spiral element **19** will cause the holders **11** to tilt about a radially extending axis as shown in **FIGS. 5 and 6**.

[0027] The spiral elements **12** and **13** can be displaced by their respective motors at the same time.

[0028] The eyelets **15** and **16** (and the spiral elements **19** and **20**) could be interchanged so that the top spiral element causes deflection about an axis at right angles to a radius and the bottom spiral element produces deflection about a radially extending axis.

[0029] A third electric motor (not shown) could be provided to push the support member **10**, together with the spiral elements **12** and **13**, from the planar condition shown in the drawings into a dome-shaped condition or to pull the support member **10**, together with the spiral elements **12** and **13**, into a bowl-shaped condition. It is for this reason that the support member **10** is formed so as to be capable of flexing.

[0030] In a preferred embodiment the holders **11** support white LED's each having blue red and green guns. They could however support fibre optics or lenses or light sensitive devices.

[0031] Referring now to **FIG. 9** of the drawings, the spiral element **12** is replated by spokes **22**. The spokes **22** are telescopically extendible and are located below the support member **10**. The spokes **22** extend radially outwards from the axis of the spiral support member **10** and are equi-angularly spaced. Each spoke **22** comprises a plurality of sleeve-like parts **23** and a plurality of rod-like parts **24** each of which is slidably mounted in two adjacent sleeve-like parts **23** thus permitting the spokes **22** to extend and retract.

The sleeve-like parts **23** are interconnected by springs **25** and the rod-like parts **24** are interconnected by springs **26**. Each holder **11** may be connected to one of the sleeve-like parts **23** by a further universal joint **27**.

[0032] The spokes **22** are angularly displaceable relative to the support member **10** by an electric motor (not shown). Such angular movement of the spokes **22** will cause the holders **11** to tilt about a radially extending axis as shown in **FIGS. 5 and 6**. The holders **11** closer to the outer periphery of the support member **10** will tilt more than the holders **11** closer to the inner periphery of the support member **10** and this will change the angle and shape of the light beam emitted by LED's supported in the holders **11**.

[0033] The motors can be operated in accordance with a computer program so that the angle adjustment device varies the lighting as required.

[0034] The angle adjustment devices described above are particularly suitable for use in automated lighting although they could have other applications.

[0035] The embodiments described above are given by way of example and various modifications will be apparent to a person skilled in the art without departing from the scope of the invention. For example, the spokes **22** or second spiral element **12** could be omitted. In this case, the holders **11** could not be tilted as shown in **FIGS. 5 and 6** but could still be tilted as shown in **FIGS. 7 and 8**. Also, the support member **10** may not be capable of flexing and may instead be of fixed planar shape or of fixed dome-like or bowl-like shape.

- 1. (canceled)
- 2. (canceled)
- 3. (canceled)
- 4. (canceled)
- 5. (canceled)
- 6. (canceled)
- 7. (canceled)
- 8. (canceled)
- 9. (canceled)
- 10. (canceled)

11. Automated lighting having a source of light formed by a plurality of light emitting diodes (LEDs) that are pivotably mounted on a support to form a shaped light beam.

12. The lighting apparatus of claim 11, wherein said LEDs are attached to said support with a joint.

13. The lighting apparatus of claim 11, wherein the source of light is a white light.

14. The lighting apparatus of claim 11 wherein the color of LED's varies and the color of the light source can be varied.

15. The lighting apparatus of claim 11, further comprising at least two elongated elements that cooperate with said LEDs and that are movable and cause pivotal motion of said LEDs.

16. The lighting apparatus of claim 11, wherein said LEDs are pivotable in directions that are at right angles to each other.

17. The lighting apparatus of claim 11, wherein the apparatus has a center axis and said LEDs are pivotable in directions that are at right angles to the center axis of the apparatus.

18. the lighting apparatus of claim 11, wherein the apparatus has a center axis and said LEDs is pivotable in directions in-line with the center axis of the apparatus.

19. The lighting apparatus of claim 11, wherein the pivoting of the LEDs results in modification of the width of the light beam formed by the LEDs.

20. The lighting apparatus of claim 11, wherein the pivoting of the LEDs results in modification of the direction of the light beam formed by the LEDs.

21. A lighting apparatus comprising a plurality of light emitting diodes (LEDs) that are pivotably mounted on support to form a shaped light beam whose characteristics change as the LEDs are pivoted.

22. The lighting apparatus of claim 21 where a characteristic of the light beam that changes as the LEDs pivot is the width of the beam.

23. The lighting apparatus of claim 21 where a characteristic of the light beam that changes as the LEDs pivot is the height of the beam.

24. The lighting apparatus of claim 21 where a characteristic of the light beam that changes as the LEDs pivot is the direction of the light beam.

25. The lighting apparatus of claim 21 where the light beam width and/or direction change as the LEDs pivot.

26. The lighting apparatus of claim 26 where the light beam is near round and the width of the beam is the beam diameter.

27. The lighting apparatus of claim 21 where the light beam height and/or width and/or direction change as the LEDs pivot.

28. The lighting apparatus of claim 21 where the color of the LEDs produce predominantly white light.

29. The lighting apparatus of claim 21 where the color of the LEDs vary and the color of the shaped light beam can be varied.

\* \* \* \* \*